

# ASPECT GONDOLA PANEL INSTRUCTIONS

ITEM # APWKIT1, APWKIT2, APWKIT3, APWKIT4, APWKIT5, APWKIT6

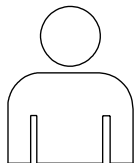
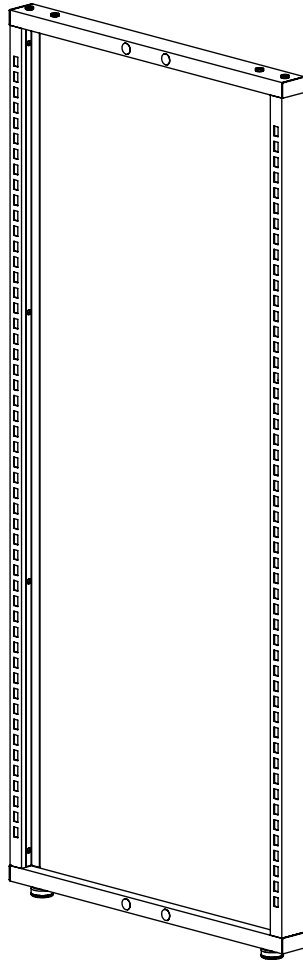

**2 PEOPLE  
REQUIRED  
FOR  
ASSEMBLY**

## PANEL KIT COMPONENTS

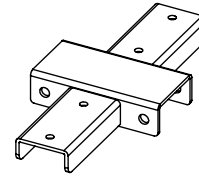

**APWCN1**  
DOUBLE SIDED CONNECTOR

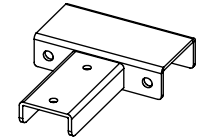

**APWCN2**  
T-SHAPED CONNECTOR

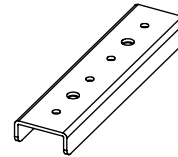

**APWCN3**  
UNION CONNECTOR

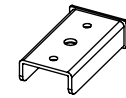

**APWCN4**  
ENDCAP

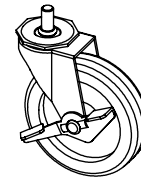

**APWCAS-1**  
CASTER

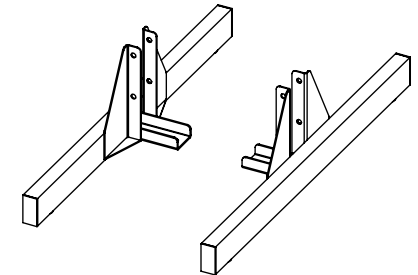

**APWSPL**  
T-LEG KIT

## REQUIRED TOOLS



**5mm ALLEN-KEY**

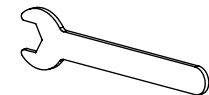

**CASTER WRENCH**

## ASSEMBLY NOTES

1. PANELS HAVE GROUPS OF (3) HOLES VS. (2) HOLES ON THE BOTTOM.
2. INSTALLING PUSH-IN RIVETS INTO UNUSED HOLES SHOULD BE THE LAST STEP. THEY ARE PURPOSELY DIFFICULT TO REMOVE.
3. TIGHTEN SCREWS WITH INCLUDED 5mm ALLEN KEY.
4. TIGHTEN CASTERS WITH INCLUDED CASTER WRENCH.
5. INCLUDED LEVELERS CAN BE USED IN PLACE OF CASTERS.

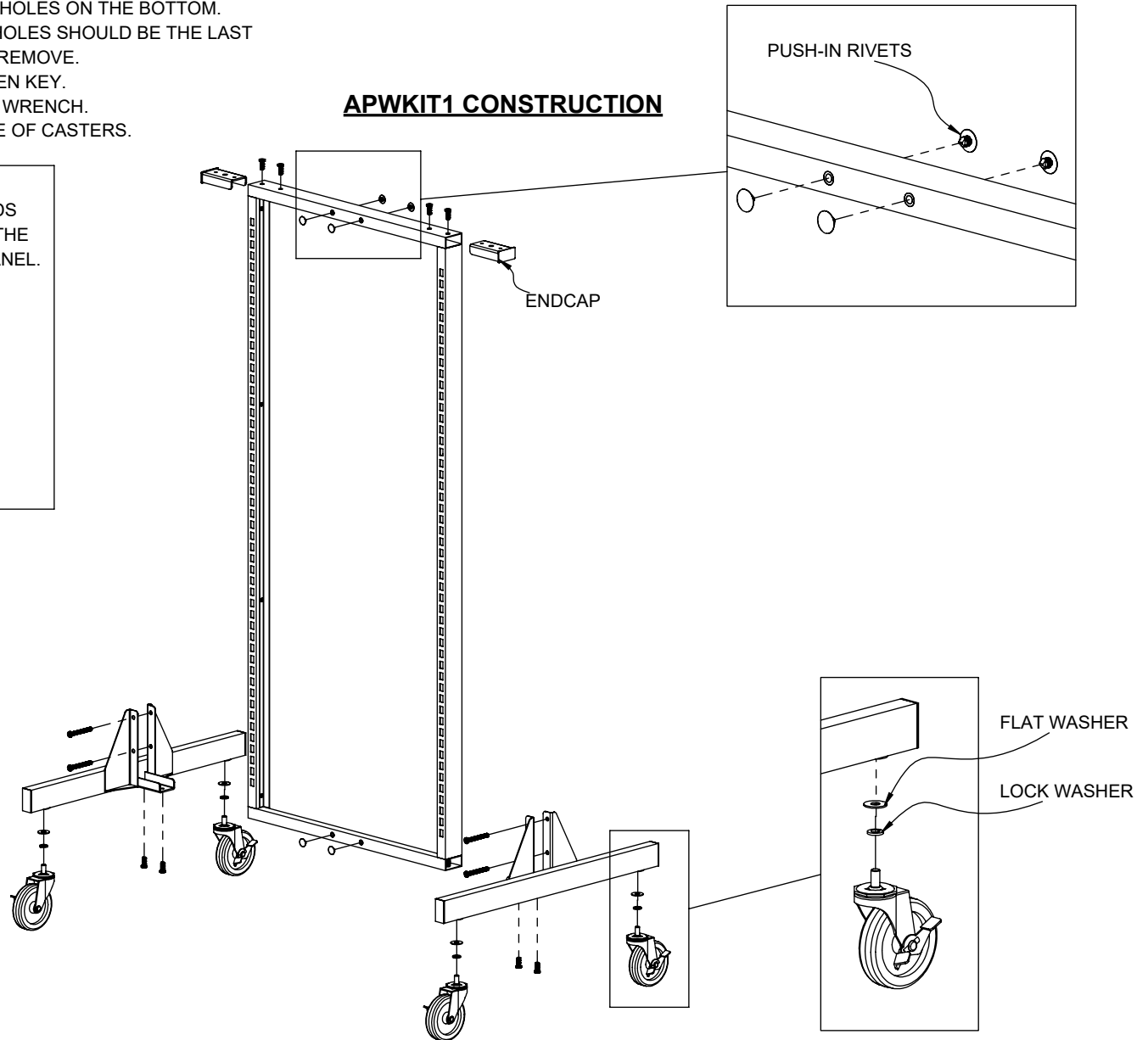
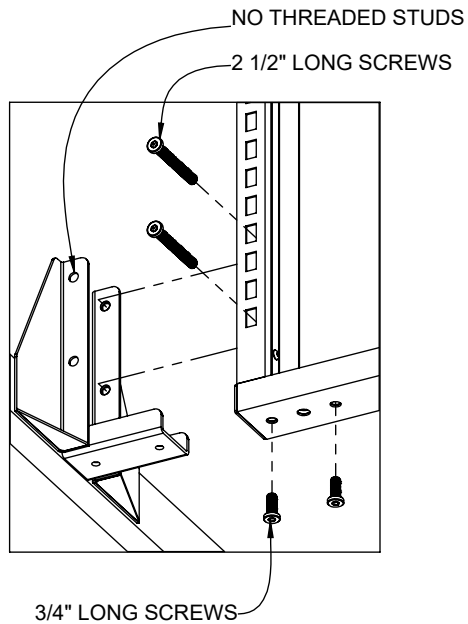
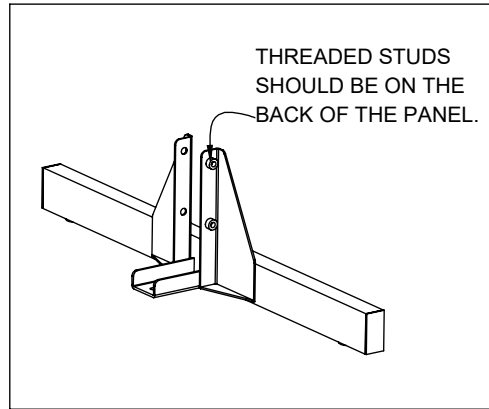

# ASSEMBLY NOTES

1. PANELS HAVE GROUPS OF (3) HOLES VS. (2) HOLES ON THE BOTTOM.
2. INSTALLING PUSH-IN RIVETS INTO UNUSED HOLES SHOULD BE THE LAST STEP. THEY ARE PURPOSELY DIFFICULT TO REMOVE.
3. TIGHTEN SCREWS WITH INCLUDED 5mm ALLEN KEY.
4. TIGHTEN CASTERS WITH INCLUDED CASTER WRENCH.
5. INCLUDED LEVELERS CAN BE USED IN PLACE OF CASTERS.

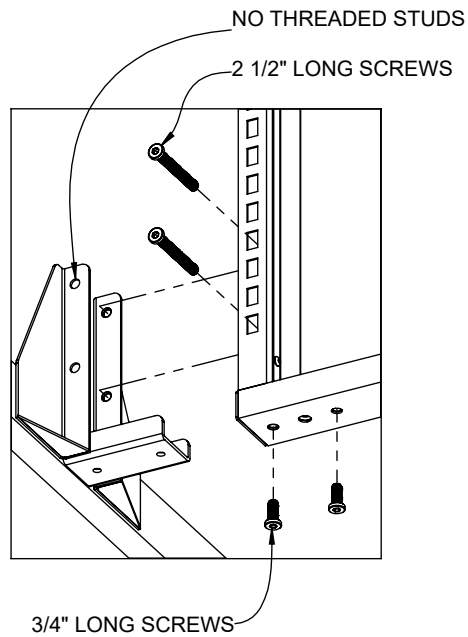
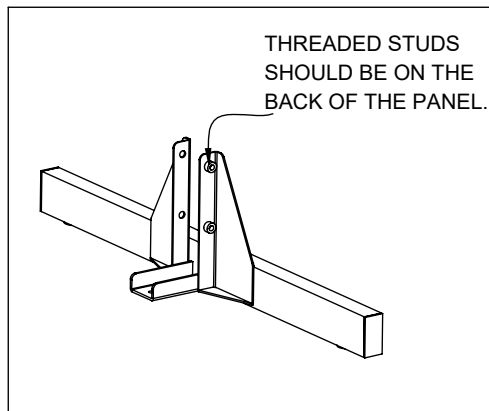

## APWKIT2 CONSTRUCTION

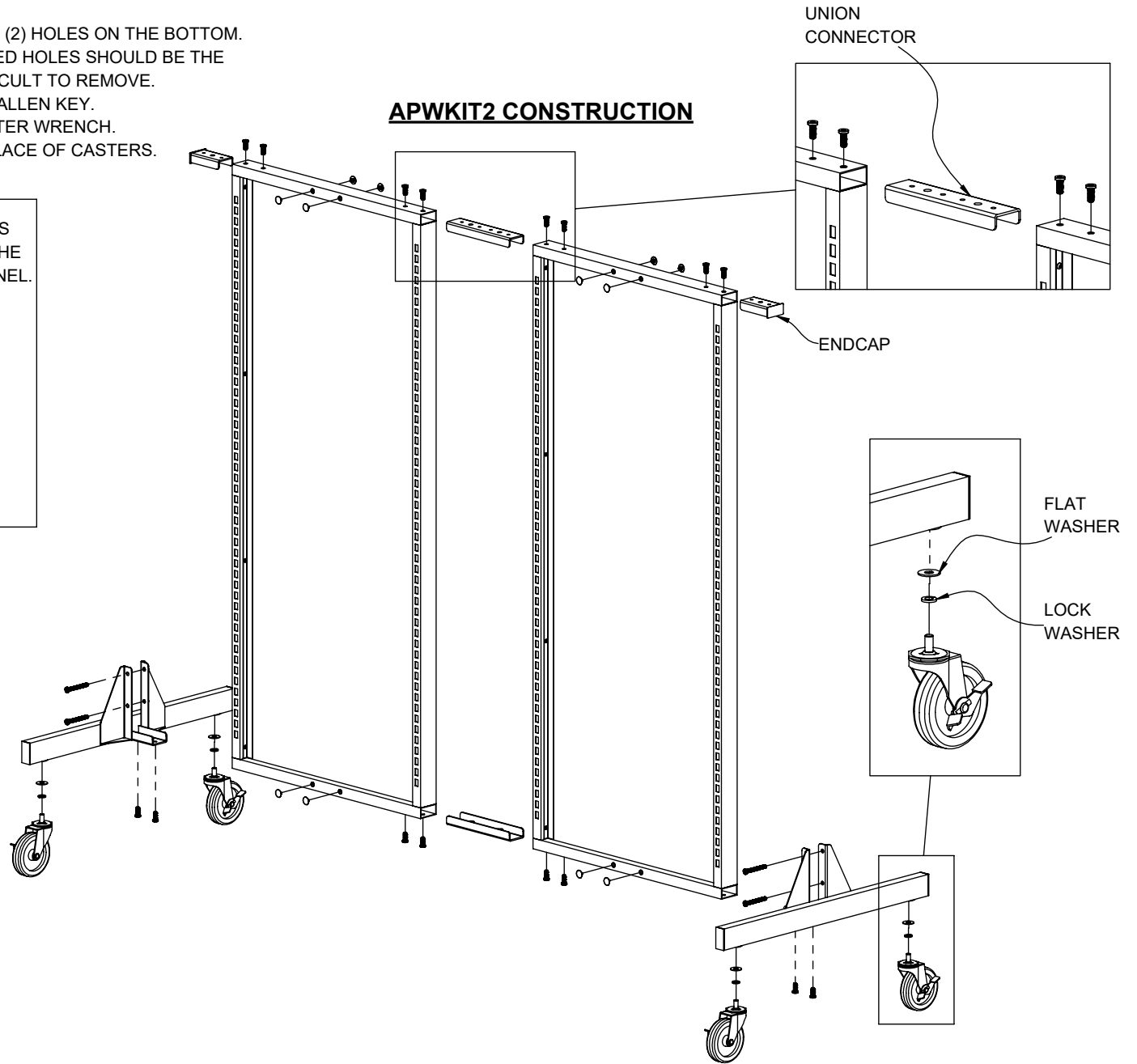

## ASSEMBLY NOTES

1. PANELS HAVE GROUPS OF (3) HOLES VS. (2) HOLES ON THE BOTTOM.
2. NO PUSH-IN RIVETS ARE REQUIRED FOR THIS KIT.
3. ENDCAPS MUST BE INSTALLED ON BOTTOM OF PANELS BEFORE CASTERS OR LEVELERS CAN BE INSTALLED.
4. TIGHTEN SCREWS WITH INCLUDED 5mm ALLEN KEY.
5. TIGHTEN CASTERS WITH INCLUDED CASTER WRENCH.
6. INCLUDED LEVELERS CAN BE USED IN PLACE OF CASTERS.

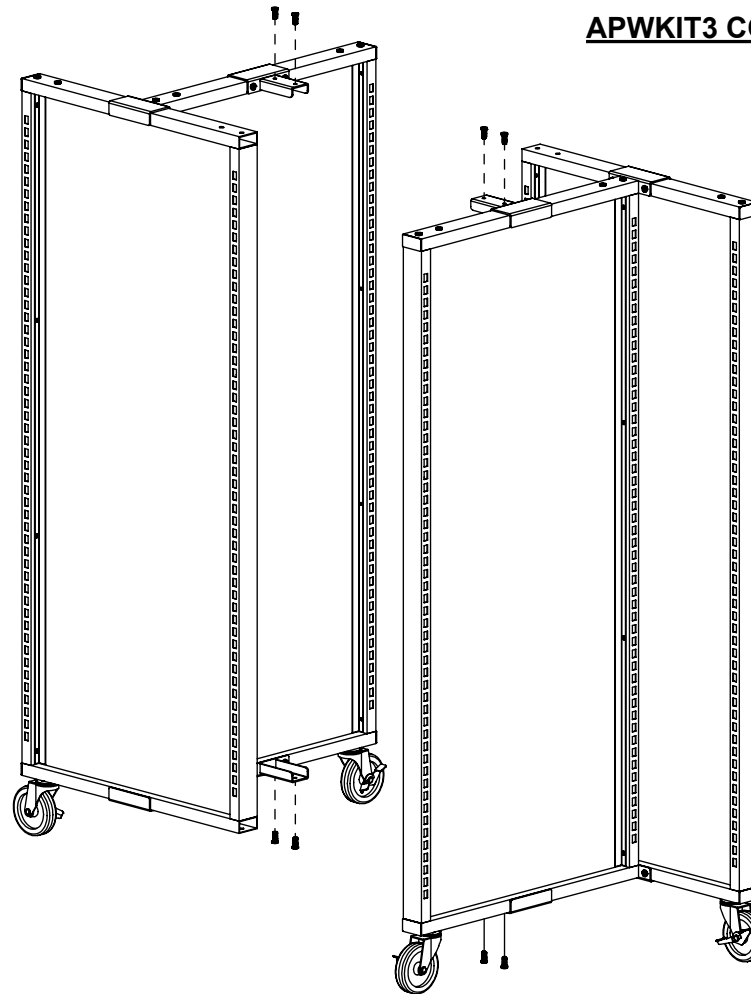
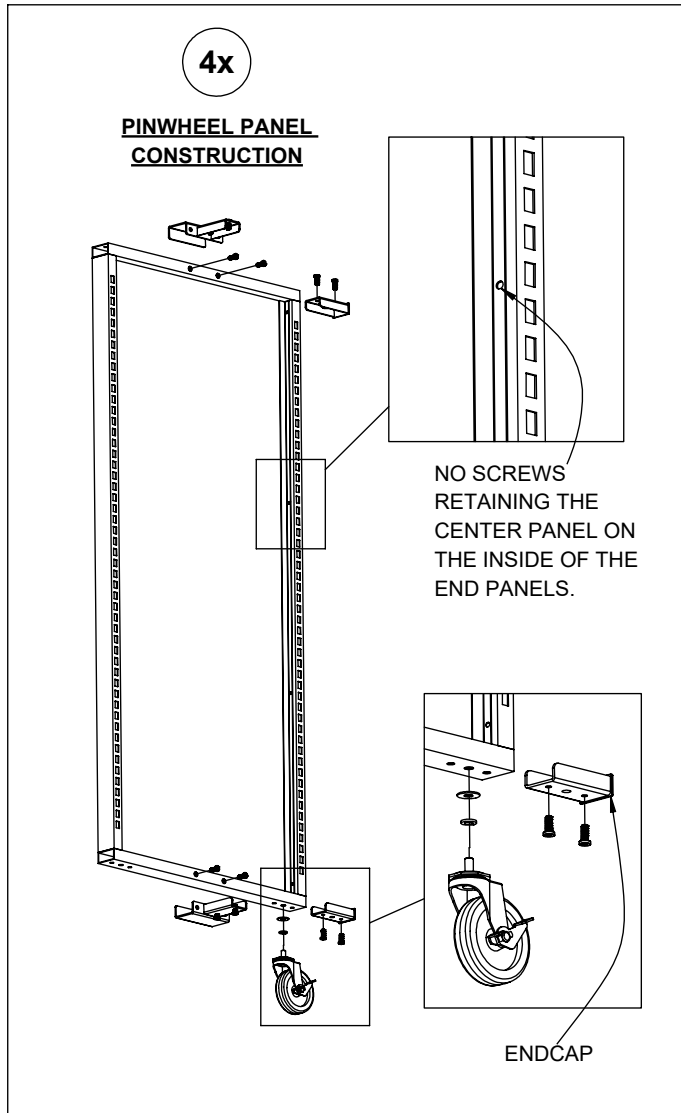

## ASSEMBLY NOTES

1. PANELS HAVE GROUPS OF (3) HOLES VS. (2) HOLES ON THE BOTTOM.
2. INSTALLING PUSH-IN RIVETS INTO UNUSED HOLES SHOULD BE THE LAST STEP. THEY ARE PURPOSELY DIFFICULT TO REMOVE.
3. ENDCAPS MUST BE INSTALLED ON BOTTOM OF PANELS BEFORE CASTERS OR LEVELERS CAN BE INSTALLED.
4. TIGHTEN SCREWS WITH INCLUDED 5mm ALLEN KEY.
5. TIGHTEN CASTERS WITH INCLUDED CASTER WRENCH.
6. INCLUDED LEVELERS CAN BE USED IN PLACE OF CASTERS.
7. THE SAME NUMBER OF END PANELS ARE REQUIRED FOR 2' AND 4' GONDOLAS.

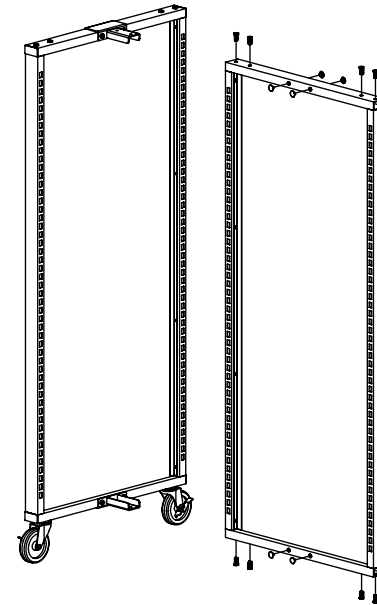
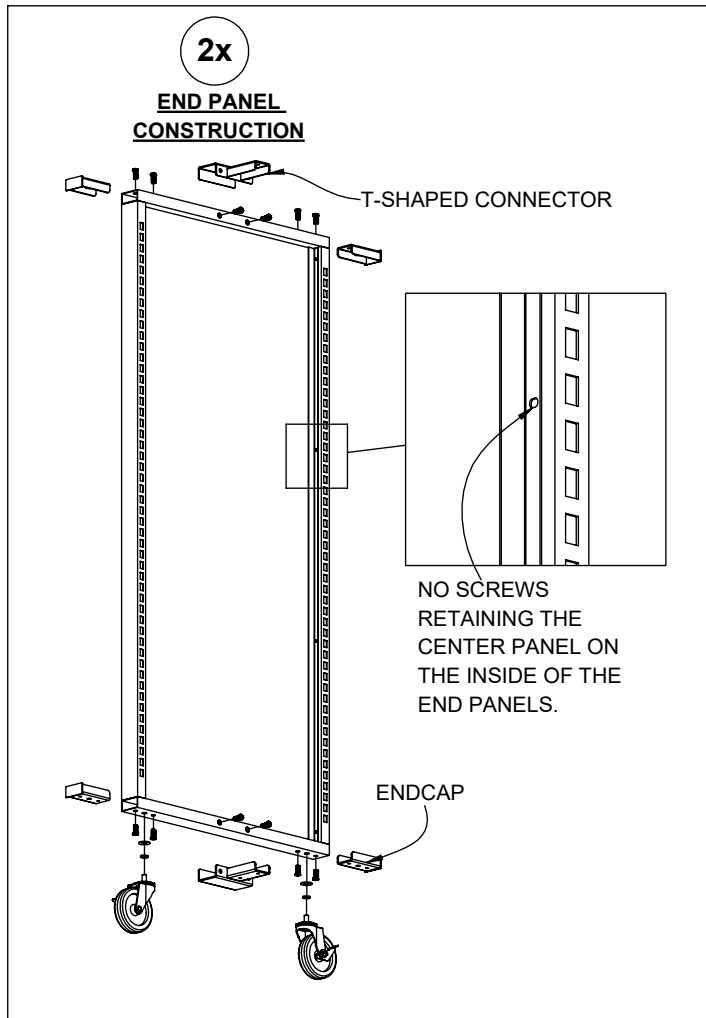

### **APWKIT4 CONSTRUCTION**

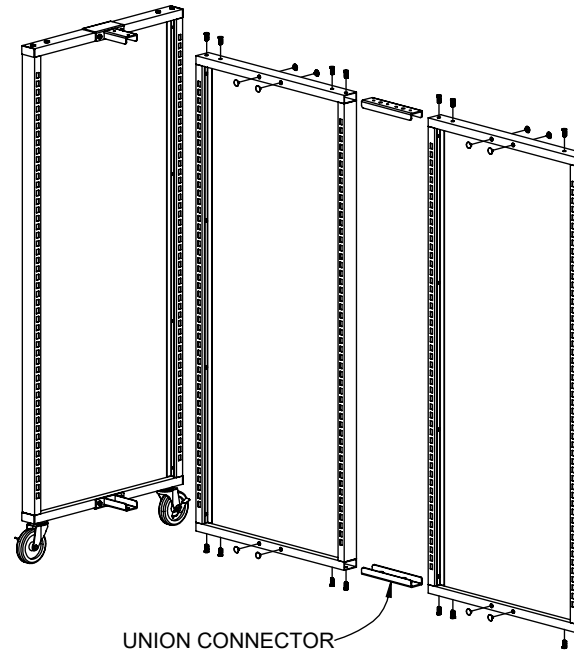
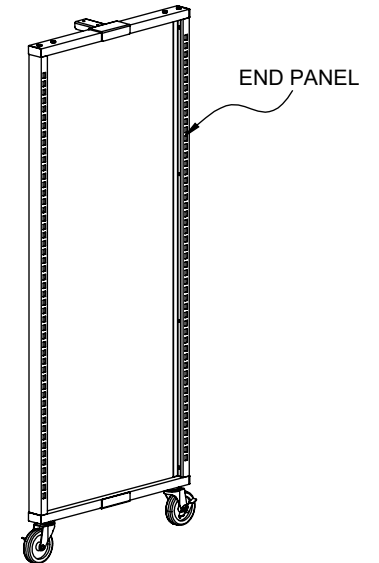

### **APWKIT5 CONSTRUCTION**

## ASSEMBLY NOTES

1. PANELS HAVE GROUPS OF (3) HOLES VS. (2) HOLES ON THE BOTTOM.
2. INSTALLING PUSH-IN RIVETS INTO UNUSED HOLES SHOULD BE THE LAST STEP. THEY ARE PURPOSELY DIFFICULT TO REMOVE.
3. ENDCAPS MUST BE INSTALLED ON BOTTOM OF PANELS BEFORE CASTERS OR LEVELERS CAN BE INSTALLED.
4. TIGHTEN SCREWS WITH INCLUDED 5mm ALLEN KEY.
5. TIGHTEN CASTERS WITH INCLUDED CASTER WRENCH.
6. INCLUDED LEVELERS CAN BE USED IN PLACE OF CASTERS
7. THIS KIT DOES NOT INCLUDE CASTERS.

