

# ASSEMBLY INSTRUCTIONS FOR: PSFS96

PIPE UNION NUT  
QTY. 4

UNTHREADED HALF OF  
PIPE UNION  
QTY. 4

THREADED HALF OF  
PIPE UNION  
QTY. 4

SHORT BRACE  
EACH INCLUDE:  
(2) LOOSE CLAMPS  
(4) HEX NUTS  
(4) CARRIAGE BOLTS  
QTY. 2

LONG BRACE  
EACH INCLUDE:  
(2) LOOSE CLAMPS  
(4) HEX NUTS  
(4) CARRIAGE BOLTS  
QTY. 1

CROSS BARS  
QTY. 4

UPRIGHTS  
QTY. 4

FLANGE LEVELER  
QTY. 4

CAP BOLTS  
QTY. 8

## INCLUDED TOOLS

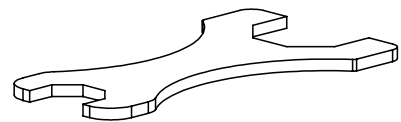

PIPE SPANNER

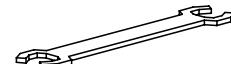

WRENCH

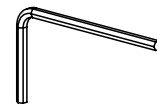

ALLEN KEY

1

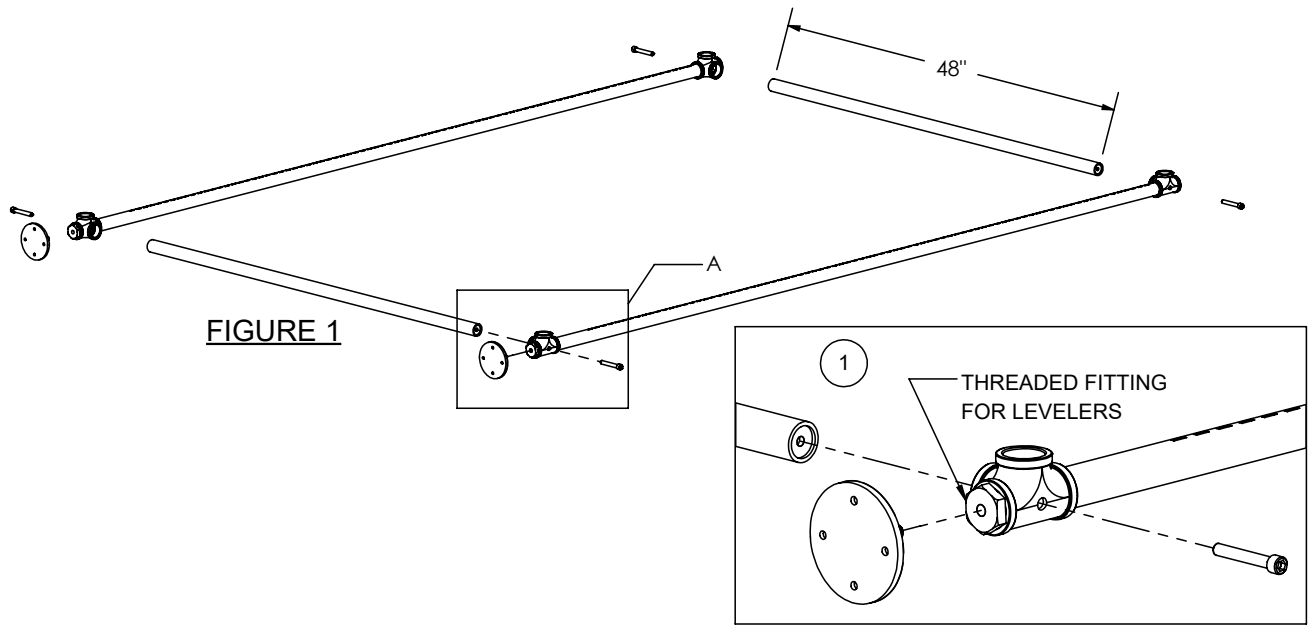

FIGURE 1

FIGURE 2

ARRANGE (2) OF THE UPRIGHTS AND (2) OF THE CROSS BARS AS SHOWN IN FIGURE 1. BE SURE THE UPRIGHTS ARE ORIENTATED WITH THE THREADED FITTINGS ON THE BOTTOM. INSTALL THE LEVELERS INTO THE THREADED FITTINGS OF THE UPRIGHTS. SECURE THE UPRIGHTS TO THE CROSS BARS WITH THE CAP BOLTS USING THE INCLUDED ALLEN KEY.

2

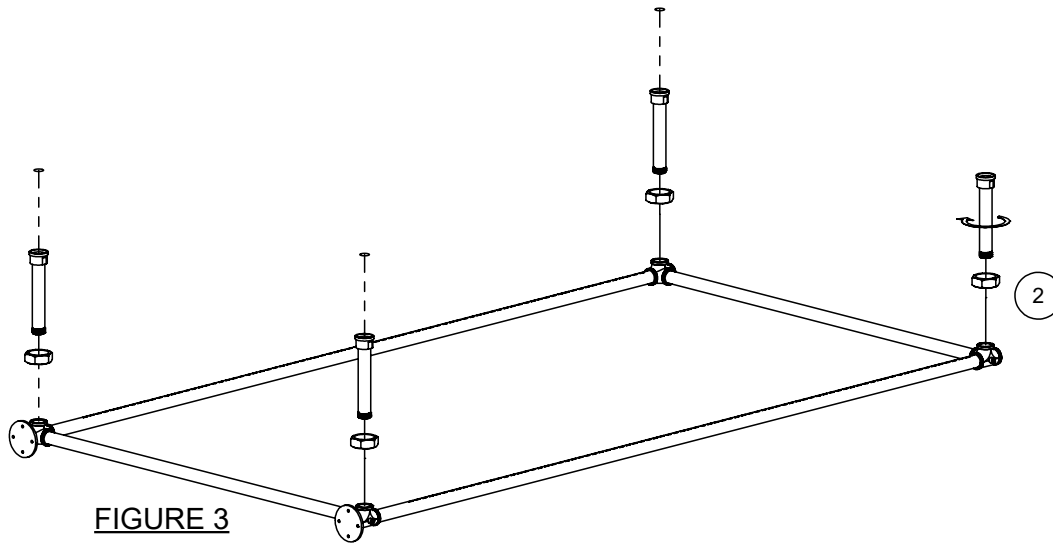

FIGURE 3

INSERT THE UNTHREADED HALF OF THE PIPE UNION THROUGH THE UNION NUT AND SCREW TO THE ASSEMBLED FRAME FROM STEP 1.

3

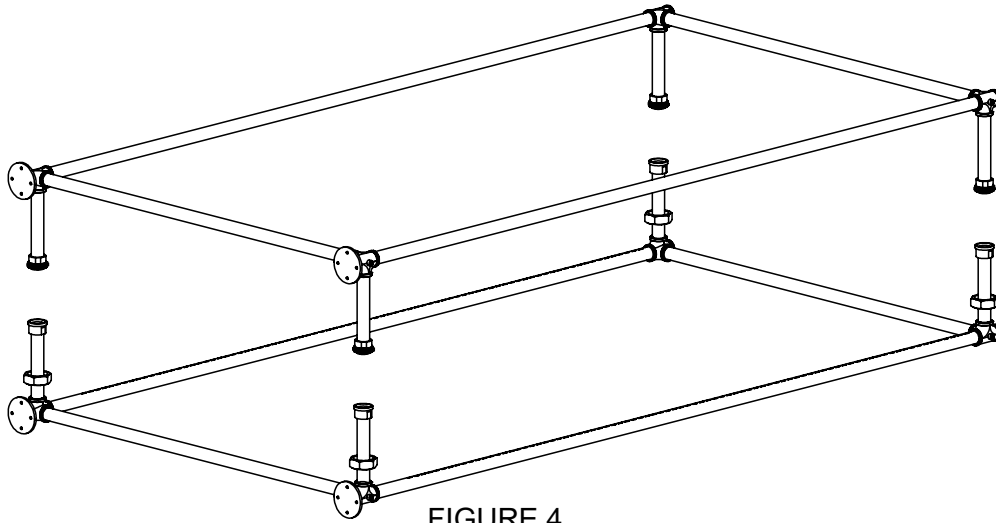

FIGURE 4

REPEAT STEPS 1 AND 2 WITH THE REMAINING CROSS BARS, UPRIGHTS, AND THREADED HALVES OF THE PIPE UNIONS. WITH AT LEAST 2 PEOPLE, JOIN THE 2 FRAME HALVES AS SEEN IN FIGURE 4. THE HALVES OF THE PIPE UNIONS SHOULD NEST TOGETHER.

4

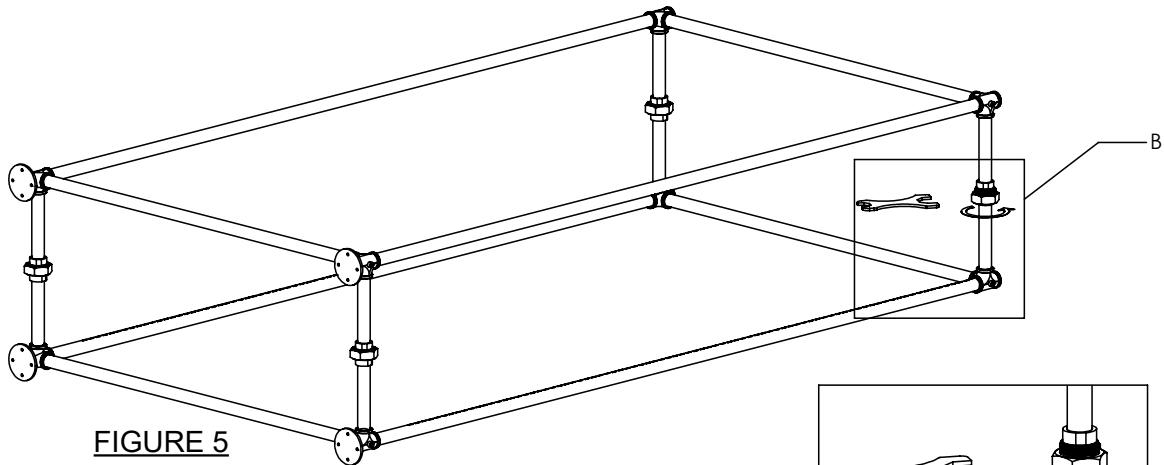

FIGURE 5

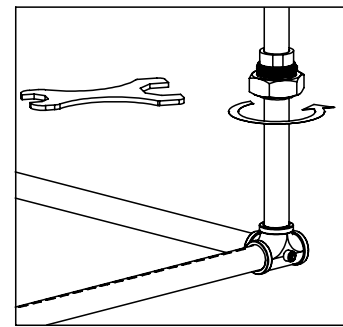

FIGURE 6

WITH THE TWO FRAME HALVES RESTING ON TOP OF EACH OTHER, BEGIN HAND TIGHTENING THE UNION NUT ONTO THE THREADED HALF OF THE PIPE UNION. REPEAT THIS FOR THE REMAINING 3 UNIONS. WHEN ALL UNIONS HAVE BEEN HAND TIGHTENED, TIGHTEN WITH THE LARGE PIPE SPANNER.

5

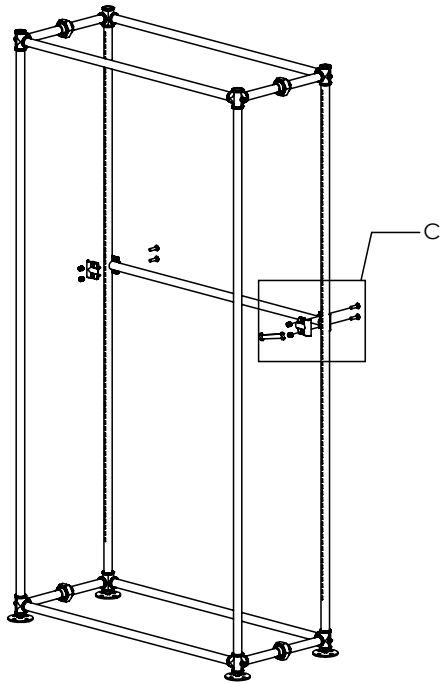

FIGURE 7

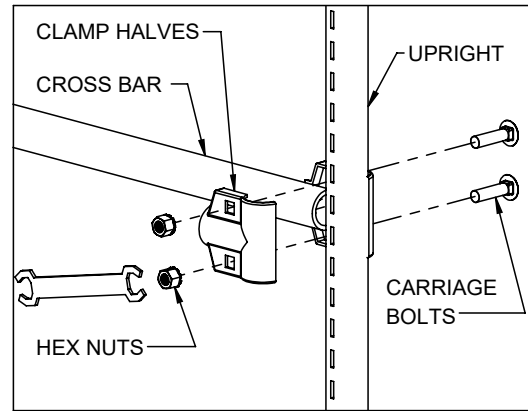

FIGURE 8

**NOTE: ALL CROSS BRACES (SHORT AND LONG) CAN BE INSTALLED ANYWHERE THAT WONT INTERFERE WITH ACCESSORY PLACEMENT.**  
FOR EACH SIDE OF THE LONG CROSS BRACE, SECURE THE PIPE CLAMP HALVES AROUND THE UPRIGHTS AND CROSS BAR WITH THE CARRIAGE BOLTS AND HEX NUTS WITH THE INCLUDED WRENCH. 2 PEOPLE MAY BE REQUIRED FOR THIS STEP.

6

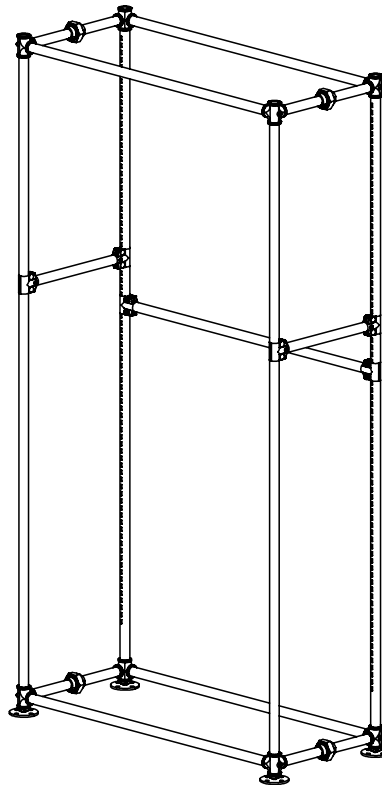

FIGURE 9

REPEAT STEP 5 FOR THE SHORT CROSS BRACES.

**ASSEMBLY INSTRUCTIONS FOR:**  
**CABINET DRAWER UNIT - PSFSMLDW(F)**

**DRAWER CABINET COMPONENT**

CABINET UNIT COMES FULLY ASSEMBLED AND WEIGHS APPROXIMATELY 100 POUNDS. PLEASE HANDLE WITH TWO PEOPLE. REMOVE FROM PACKAGE AND GENTLY LAY BOTTOM BRACKETS OF CABINET UNIT ON TO SIDE CROSS BARS OF THE FREESTANDING MERCHANDISING UNIT. THE WEIGHT OF THE UNIT KEEPS IT FROM MOVING.



**ASSEMBLY INSTRUCTIONS:  
PSORSLF48/24-ML**

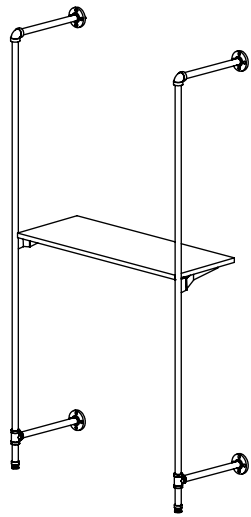

SHOWN INSTALLED  
ON ITEM# PSOR FOR  
REFERENCE

ITEM# PSORSLF48/24-ML

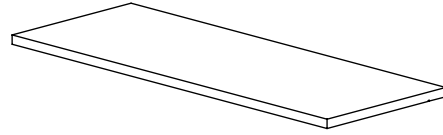

ITEM# PSORKB  
(SOLD SEPARATELY)

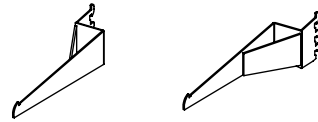

**1**

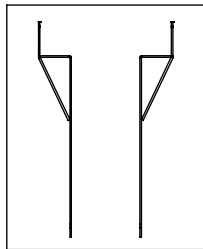

SHELF BRACKETS  
VIEWED FROM BELOW

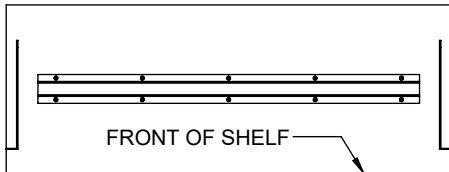

SHELF VIEWED FROM BELOW  
**(NOTE: THE PSORSLF24-ML DOES  
NOT HAVE A STEEL SUPPORT)**

IDENTIFY THE LEFT AND  
RIGHT BRACKETS. THE  
BEND OF THE SHELF  
BRACKETS SHOULD BE  
BETWEEN TWO OUTRIGGER  
UPRIGHTS.

IDENTIFY THE FRONT OF  
THE SHELF.

**2**

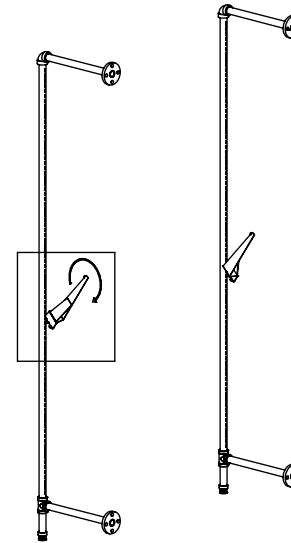

TILT THE SHELF BRACKET UP AND  
INSERT THE TOP TOOTH INTO THE  
DESIRED SLOT AS SHOWN. ROTATE  
THE BRACKET DOWN WHILE  
PUSHING TOWARDS THE UPRIGHT  
SO ALL OF THE BRACKET TEETH  
ENGAGE THE SLOTTED  
STANDARDS. REPEAT FOR THE  
OTHER BRACKET AT THE SAME  
HEIGHT.

**3**

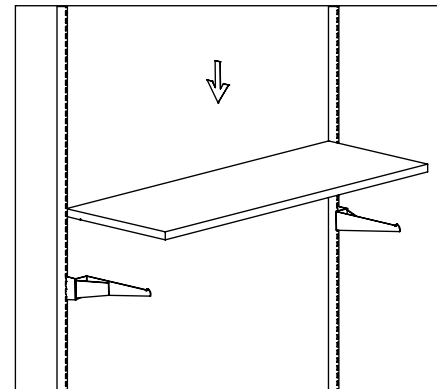

DROP THE SHELF ONTO THE  
INSTALLED BRACKETS SO THE  
BRACKETS ENGAGE THE  
ROUTE ON THE BOTTOM OF  
THE SHELF WOOD.