

ASSEMBLY INSTRUCTIONS FOR: PSFS96

PIPE UNION NUT
QTY. 4

UNTHREADED HALF OF
PIPE UNION
QTY. 4

THREADED HALF OF
PIPE UNION
QTY. 4

SHORT BRACE
EACH INCLUDE:
(2) LOOSE CLAMPS
(4) HEX NUTS
(4) CARRIAGE BOLTS
QTY. 2

LONG BRACE
EACH INCLUDE:
(2) LOOSE CLAMPS
(4) HEX NUTS
(4) CARRIAGE BOLTS
QTY. 1

CROSS BARS
QTY. 4

UPRIGHTS
QTY. 4

FLANGE LEVELER
QTY. 4

CAP BOLTS
QTY. 8

INCLUDED TOOLS

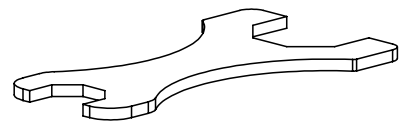

PIPE SPANNER



WRENCH

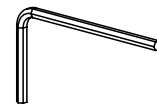

ALLEN KEY

1

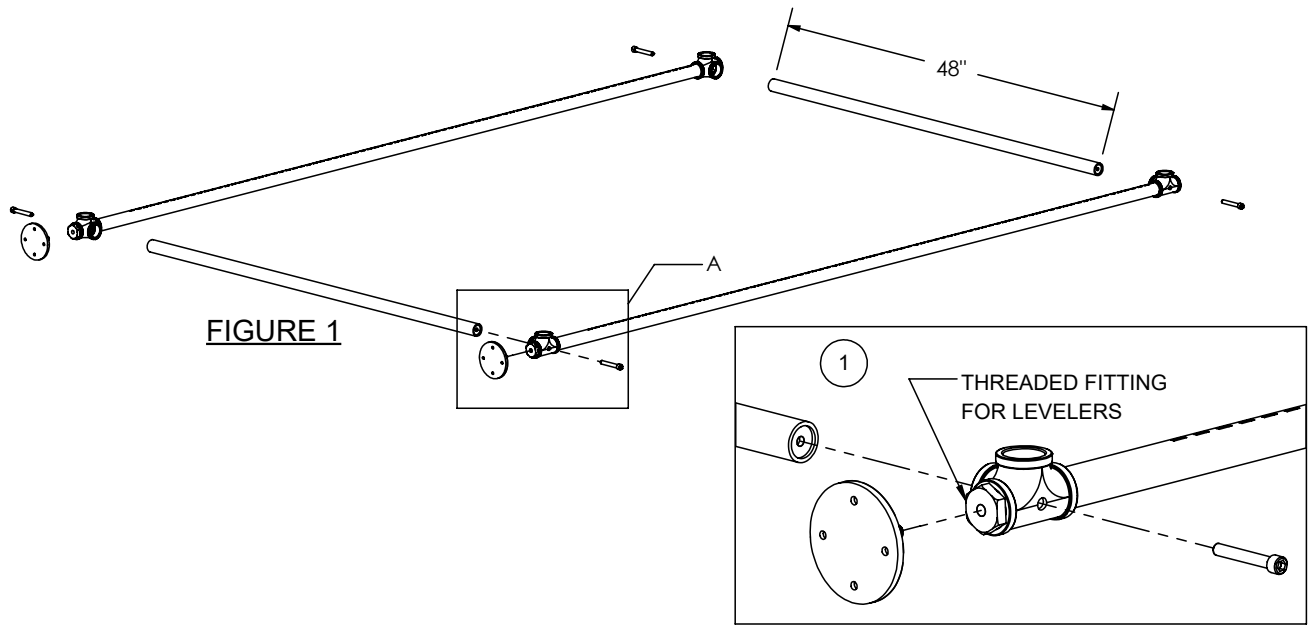

FIGURE 1

FIGURE 2

ARRANGE (2) OF THE UPRIGHTS AND (2) OF THE CROSS BARS AS SHOWN IN FIGURE 1. BE SURE THE UPRIGHTS ARE ORIENTATED WITH THE THREADED FITTINGS ON THE BOTTOM. INSTALL THE LEVELERS INTO THE THREADED FITTINGS OF THE UPRIGHTS. SECURE THE UPRIGHTS TO THE CROSS BARS WITH THE CAP BOLTS USING THE INCLUDED ALLEN KEY.

2

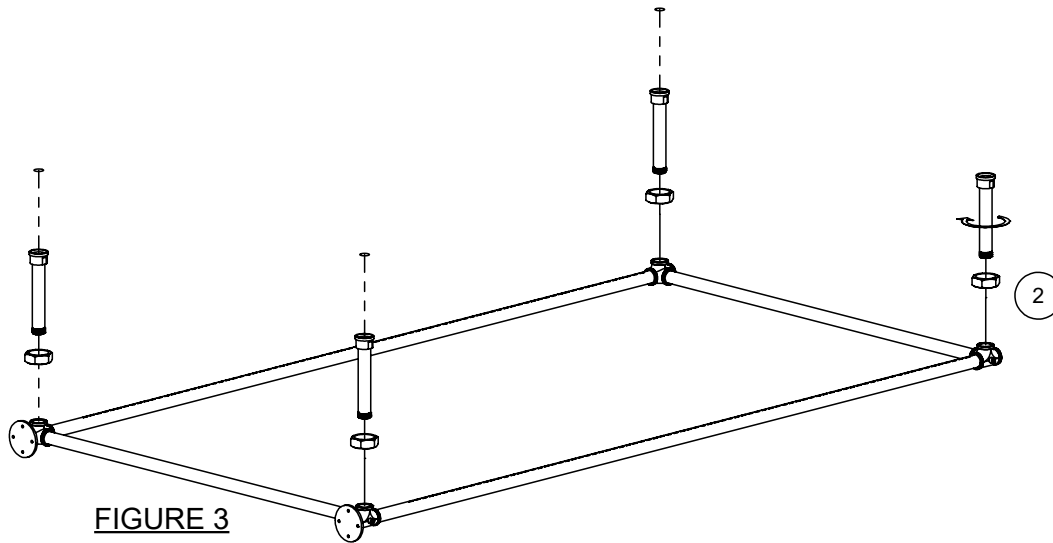

FIGURE 3

INSERT THE UNTHREADED HALF OF THE PIPE UNION THROUGH THE UNION NUT AND SCREW TO THE ASSEMBLED FRAME FROM STEP 1.

3

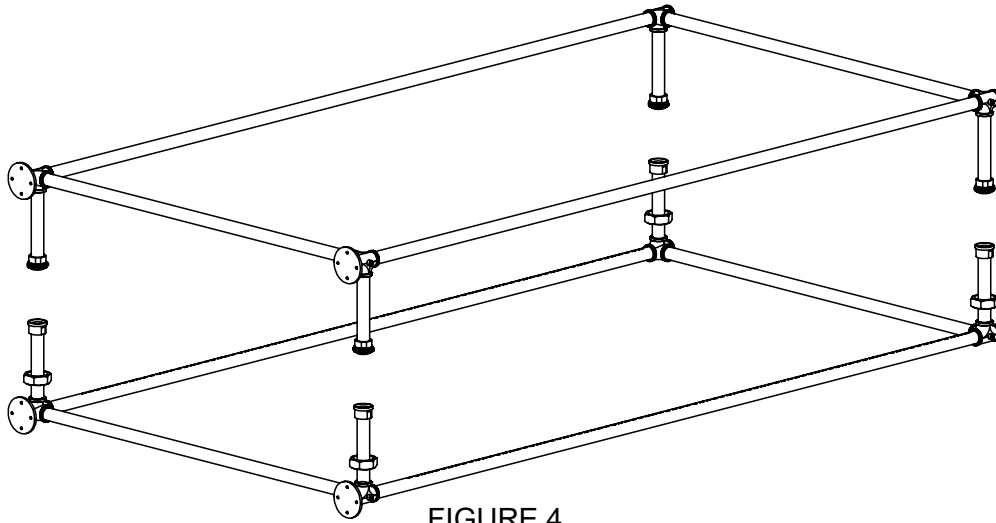

FIGURE 4

REPEAT STEPS 1 AND 2 WITH THE REMAINING CROSS BARS, UPRIGHTS, AND THREADED HALVES OF THE PIPE UNIONS. WITH AT LEAST 2 PEOPLE, JOIN THE 2 FRAME HALVES AS SEEN IN FIGURE 4. THE HALVES OF THE PIPE UNIONS SHOULD NEST TOGETHER.

4

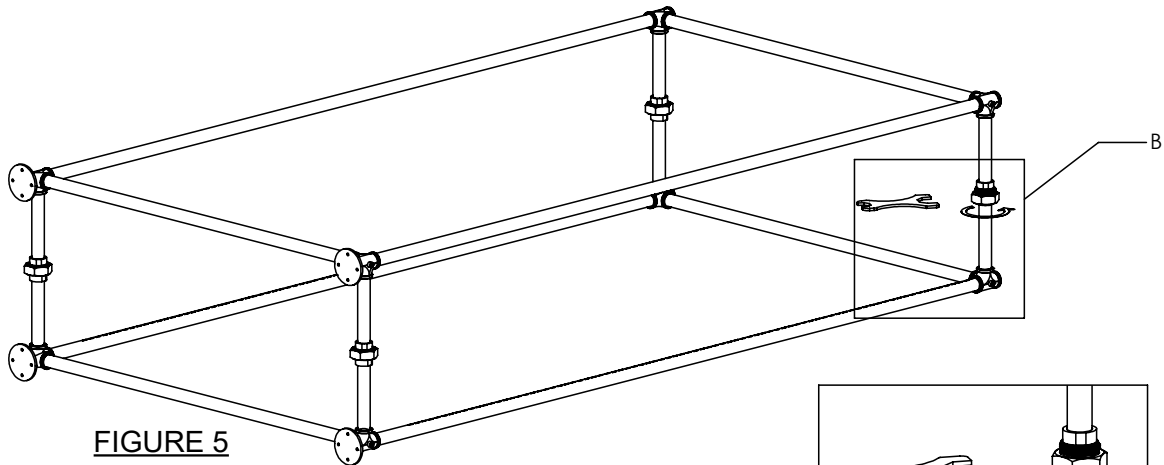

FIGURE 5

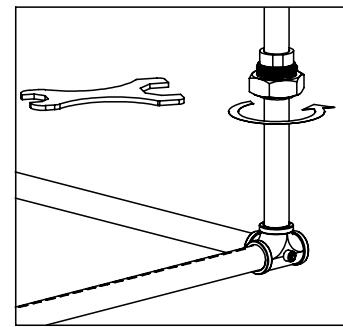

FIGURE 6

WITH THE TWO FRAME HALVES RESTING ON TOP OF EACH OTHER, BEGIN HAND TIGHTENING THE UNION NUT ONTO THE THREADED HALF OF THE PIPE UNION. REPEAT THIS FOR THE REMAINING 3 UNIONS. WHEN ALL UNIONS HAVE BEEN HAND TIGHTENED, TIGHTEN WITH THE LARGE PIPE SPANNER.

5

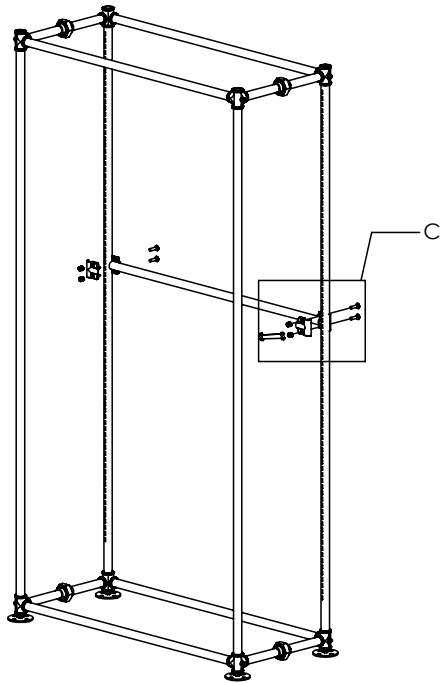

FIGURE 7

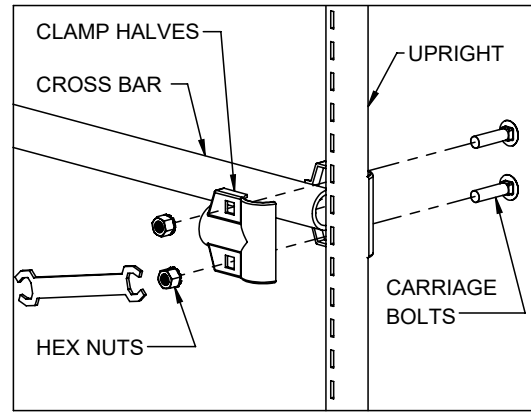

FIGURE 8

NOTE: ALL CROSS BRACES (SHORT AND LONG) CAN BE INSTALLED ANYWHERE THAT WONT INTERFERE WITH ACCESSORY PLACEMENT.
FOR EACH SIDE OF THE LONG CROSS BRACE, SECURE THE PIPE CLAMP HALVES AROUND THE UPRIGHTS AND CROSS BAR WITH THE CARRIAGE BOLTS AND HEX NUTS WITH THE INCLUDED WRENCH. 2 PEOPLE MAY BE REQUIRED FOR THIS STEP.

6

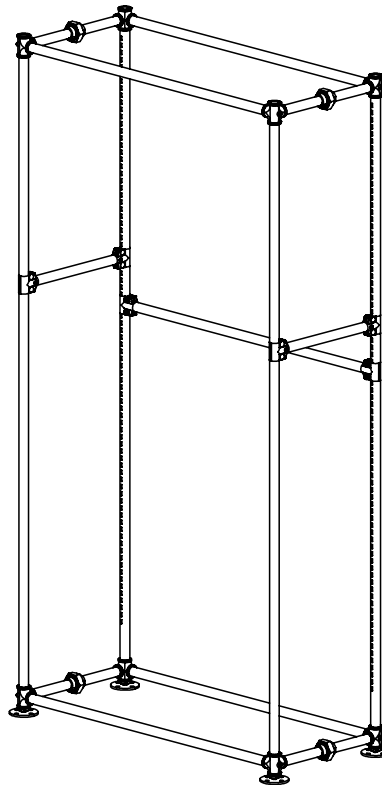

FIGURE 9

REPEAT STEP 5 FOR THE SHORT CROSS BRACES.

ASSEMBLY INSTRUCTIONS FOR:
CABINET DRAWER UNIT - PSFSMLDW(F)

DRAWER CABINET COMPONENT

CABINET UNIT COMES FULLY ASSEMBLED AND WEIGHS APPROXIMATELY 100 POUNDS. PLEASE HANDLE WITH TWO PEOPLE. REMOVE FROM PACKAGE AND GENTLY LAY BOTTOM BRACKETS OF CABINET UNIT ON TO SIDE CROSS BARS OF THE FREESTANDING MERCHANDISING UNIT. THE WEIGHT OF THE UNIT KEEPS IT FROM MOVING.



TV MOUNT FOR PIPE SYSTEM FOR 50" DISPLAY MAXIMUM

ITEM # PSFSTV-F

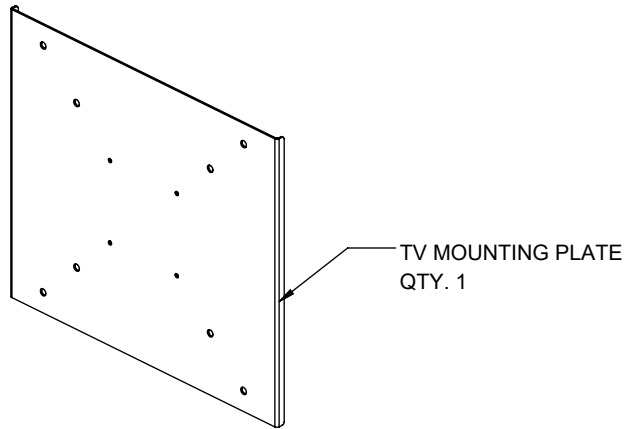
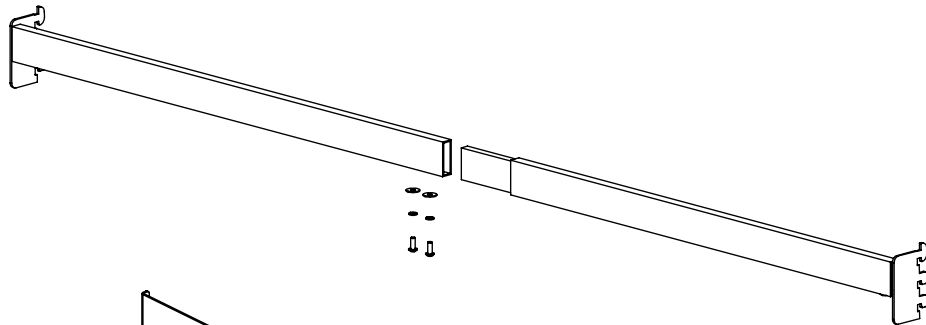
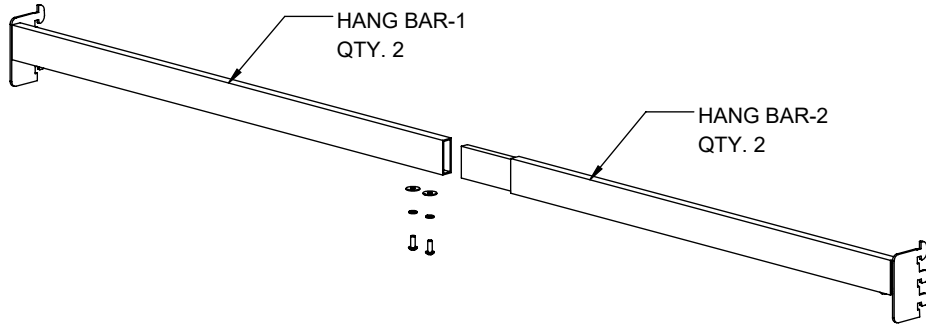

INCLUDED HARDWARE (FOR HANG BAR ASSEMBLY)

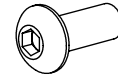

4X
SOCKET HEAD SCREW



4X
LOCK WASHER

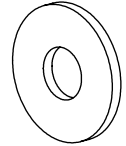

4X
WASHER

TOOLS REQUIRED



ALLEN KEY

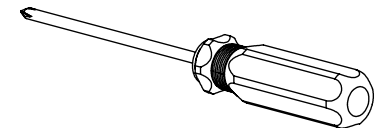

**PHILLIPS HEAD SCREW
DRIVER
(NOT INCLUDED)**

DETERMINE WHICH ASSEMBLY YOU REQUIRE

NOTE: MAX DISPLAY SIZE IS 50"

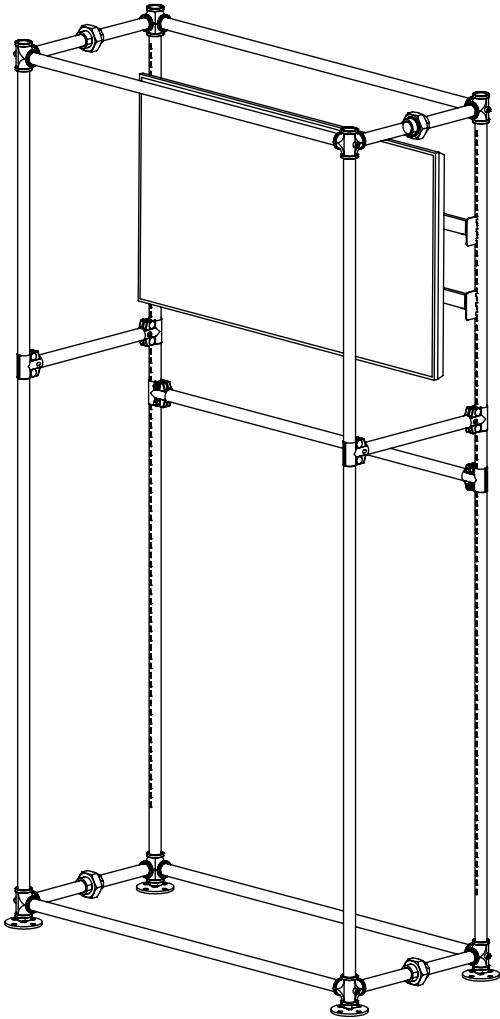

REAR MOUNT ON ON PSFS96

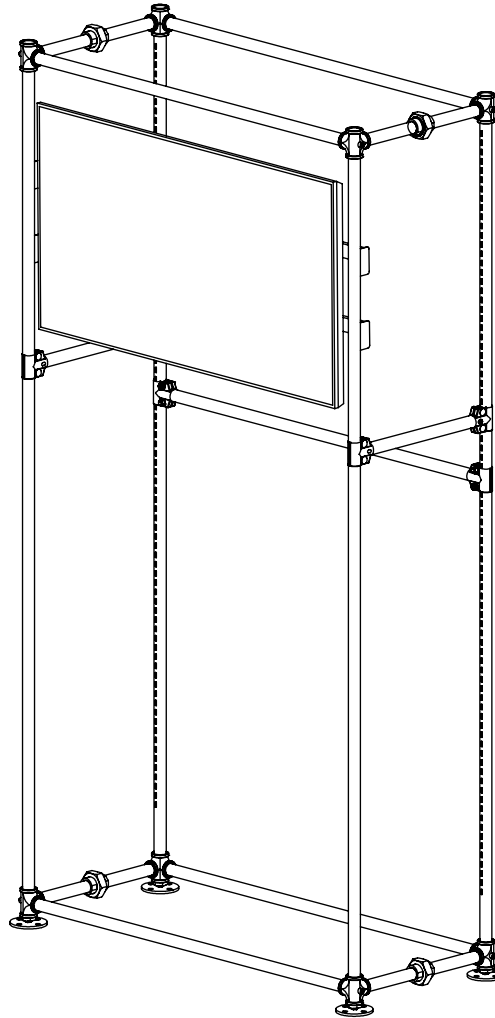

FRONT MOUNT ON ON PSFS96

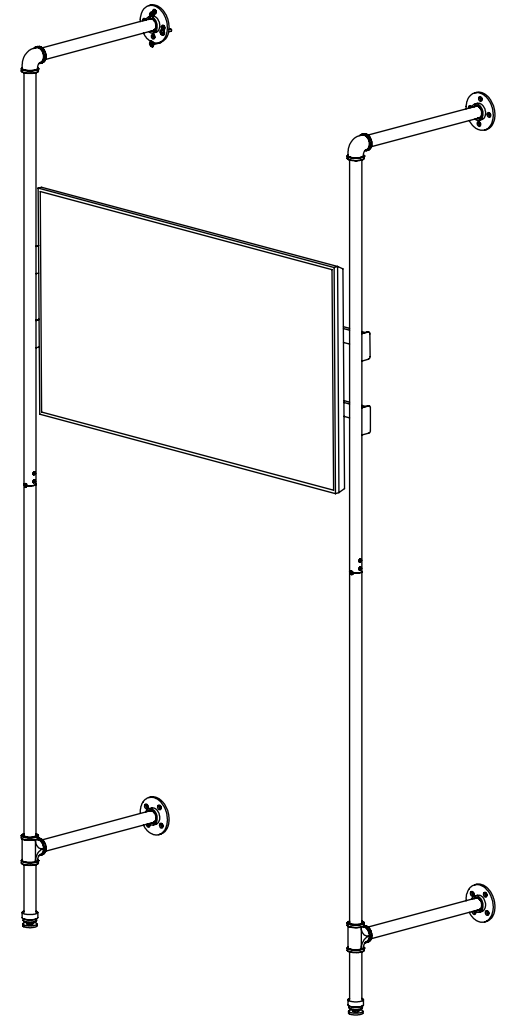

MOUNT ON PSOR

HANG BAR ASSEMBLY

1

INSERT HANG BAR-2 INTO HANG BAR-1

SECURE WITH HARDWARE AS SHOWN

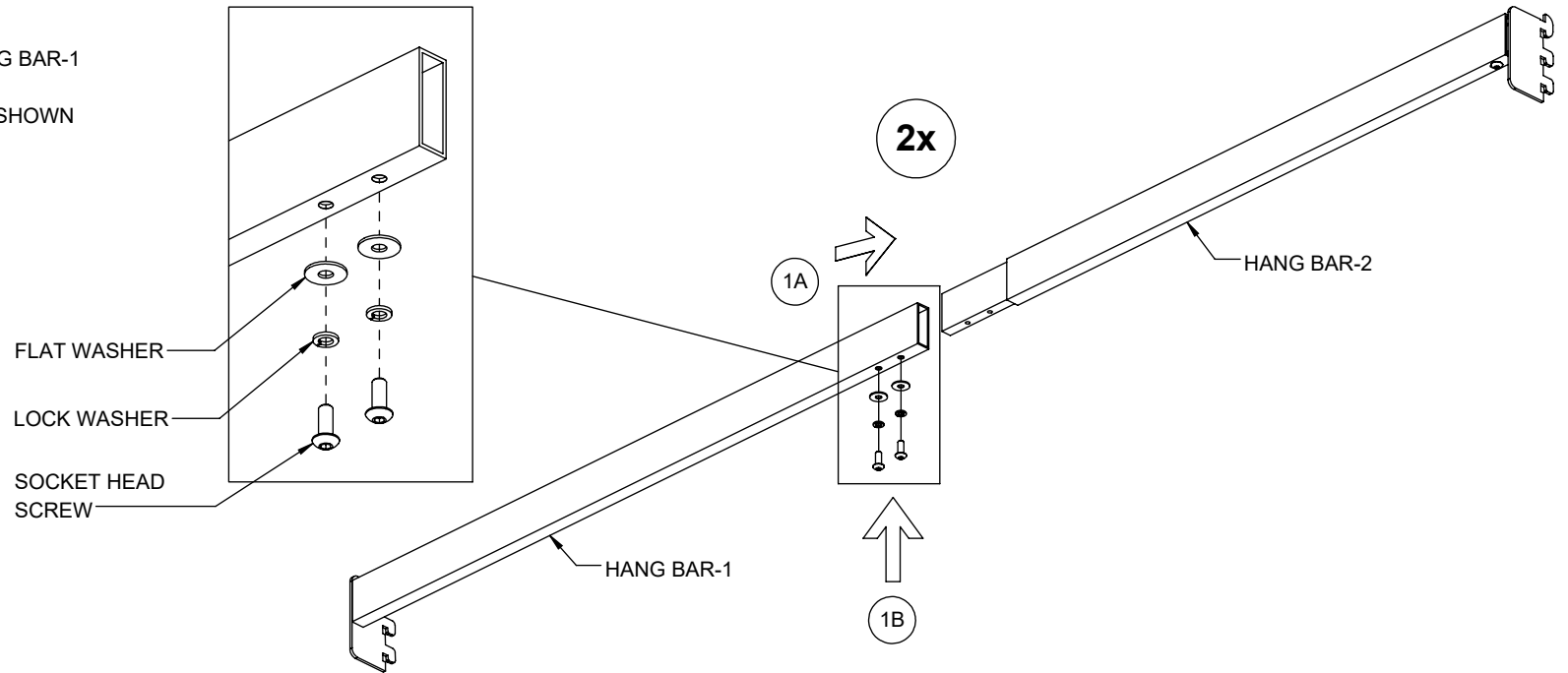

2

HANG BAR ASSEMBLIES ONTO PIPE FIXTURE 9 SLOTS APART.

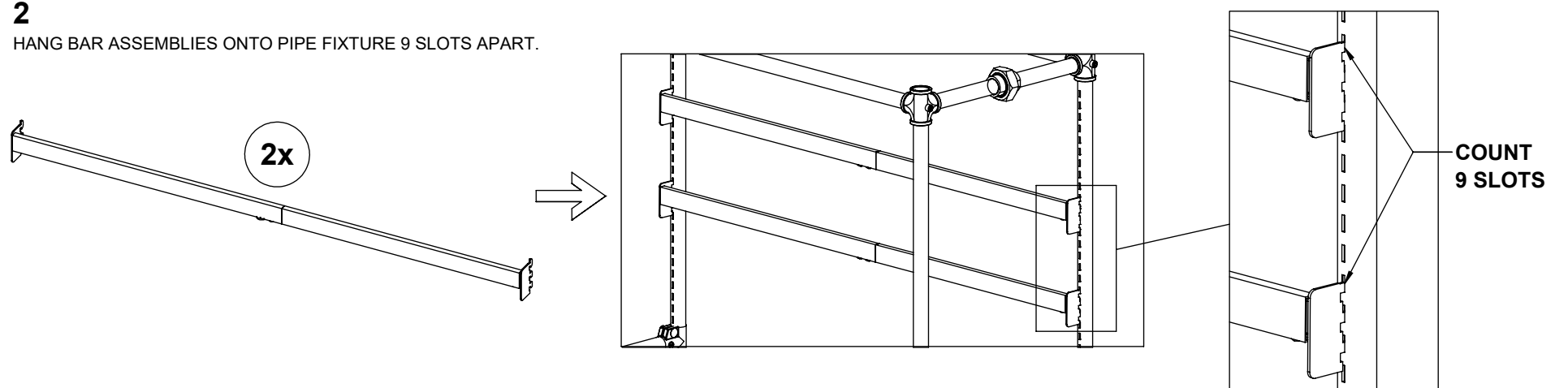

DETERMINE HARDWARE TO SECURE MOUNTING PLATE TO T.V.

1

IDENTIFY THE TYPE OF TV BACKING.

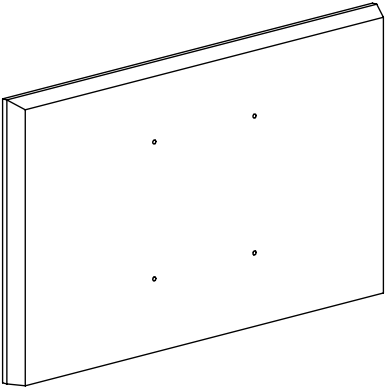
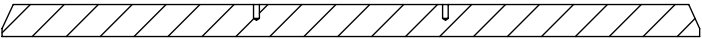

FLAT BACK

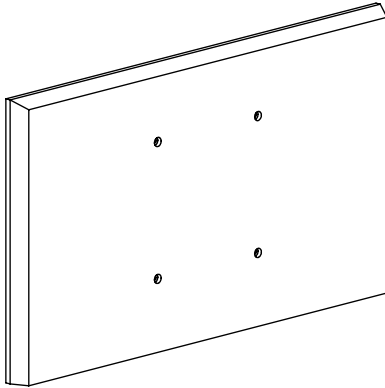
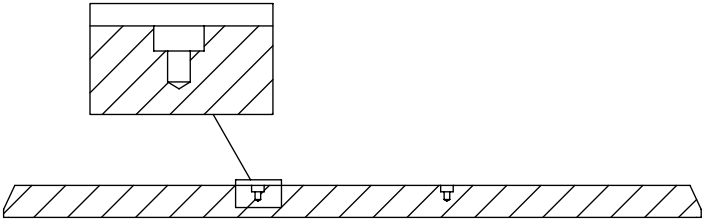

INSET HOLES

NOTE:
TV MOUNTING
PLATE FITS VESA
PATTERN SIZES:
100 X 100
200 X 200
300 X 300

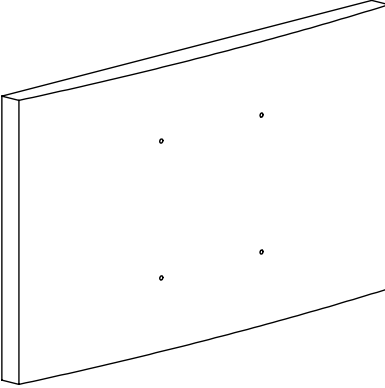

CURVED BACK

DETERMINE HARDWARE TO SECURE MOUNTING PLATE TO T.V.

2

TEST HARDWARE SIZES AND LENGTHS FROM WHAT IS INCLUDED IN THIS KIT.

| TV MOUNT HARDWARE | VESA PATTERN | QTY. |
|-------------------|-------------------------|------|
| M4 X 12mm SCREW | 100 x 100 | 4 |
| M4 X 35mm SCREW | 100 x 100 | 4 |
| M5 x 12mm SCREW | 200 x 200 | 4 |
| M5 x 35mm SCREW | 200 x 200 | 4 |
| M4/M5 WASHER | 100 x 100 | 4 |
| M6 X 12MM SCREW | 200 x 200 | 4 |
| M6 x 35mm SCREW | 200 x 200 | 4 |
| M8 x 16mm SCREW | 300 x 300 | 4 |
| M8 x 20mm SCREW | 300 x 300 | 4 |
| M8 X 35mm SCREW | 300 x 300 | 4 |
| M6/8 WASHER | 200 x 200/ 300 X 300 | 4 |
| PLASTIC SPACER | | 4 |

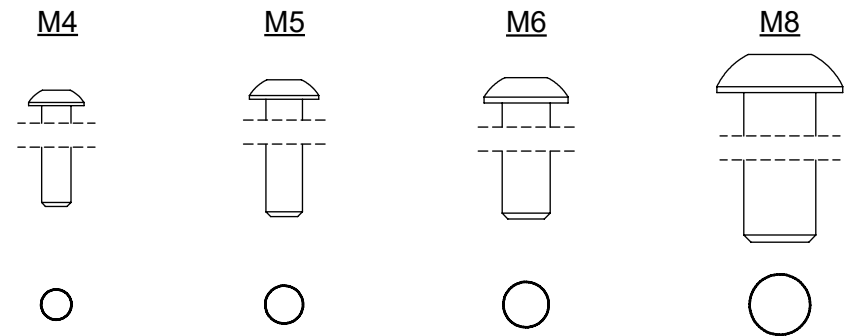
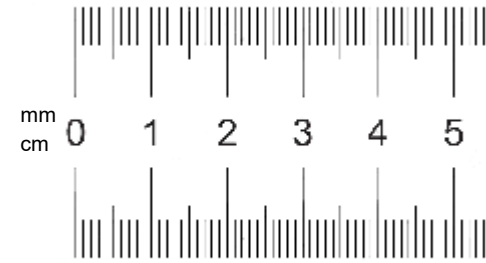

M4/M5 WASHER

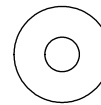

M6/M8 WASHER

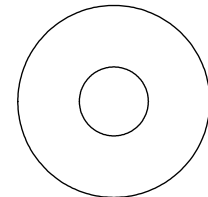

PLASTIC SPACER

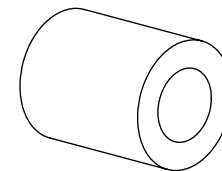

DETERMINE HARDWARE TO SECURE MOUNTING PLATE TO T.V.

3

DETERMINE IF SPACERS ARE NEEDED

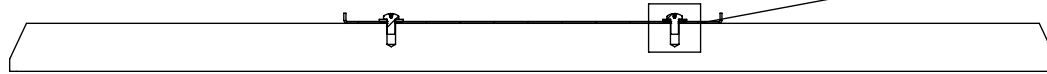

FLAT BACK TV: GO TO STEP 3A

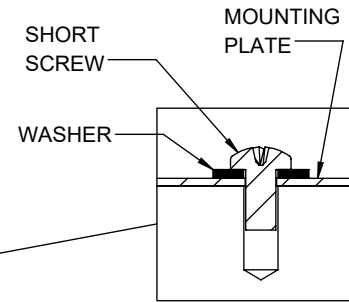

INSET HOLES: GO TO STEP 3B

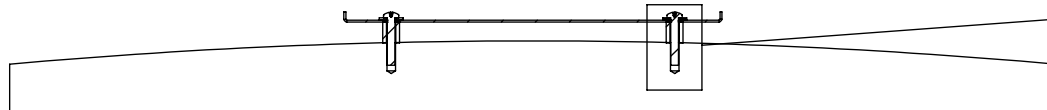
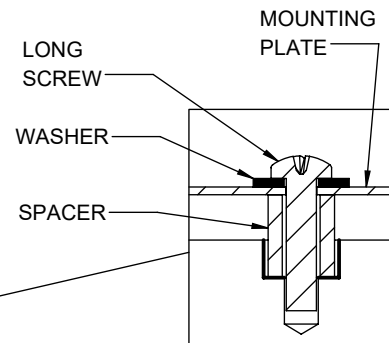

CURVED TV: GO TO STEP 3B

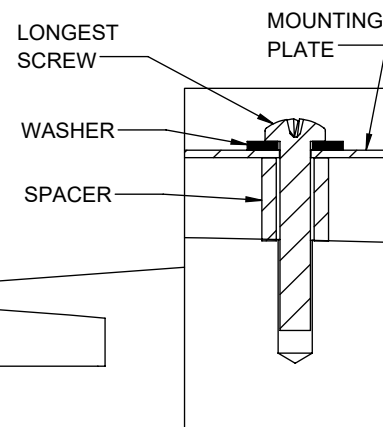

SELECT CORRECT SCREW SIZE FROM TV MOUNTING HARDWARE BAG. SELECT THE LONGEST SCREW LENGTH THAT WILL FIT AND TIGHTEN TV BRACKETS AGAINST TV.

IF SCREWS ARE TOO SHORT THEY WILL NOT THREAD INTO THE HOLES ON THE TV.

IF SCREWS ARE TOO LONG, TV BRACKETS WILL NOT TIGHTEN AGAINST TV.

IT IS POSSIBLE THAT NO COMBINATIONS OF THE PROVIDED HARDWARE WORK FOR YOUR TV BRAND.

IF THIS IS THE CASE, PLEASE CONTACT THE MANUFACTURER OF THIS MOUNTING KIT FOR ASSISTANCE.

SECURE MOUNTING PLATE TO T.V.

1

FOR TV's THAT DO NOT REQUIRE SPACERS

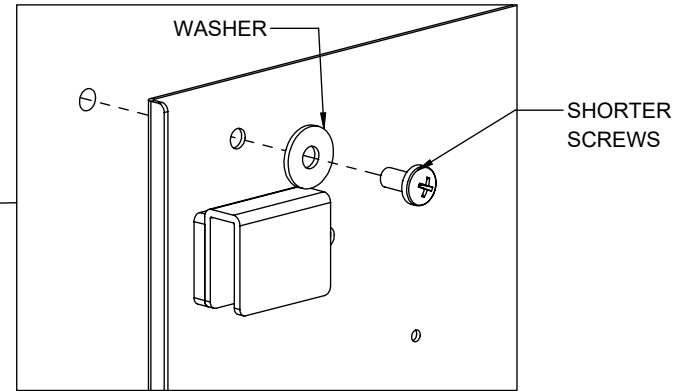
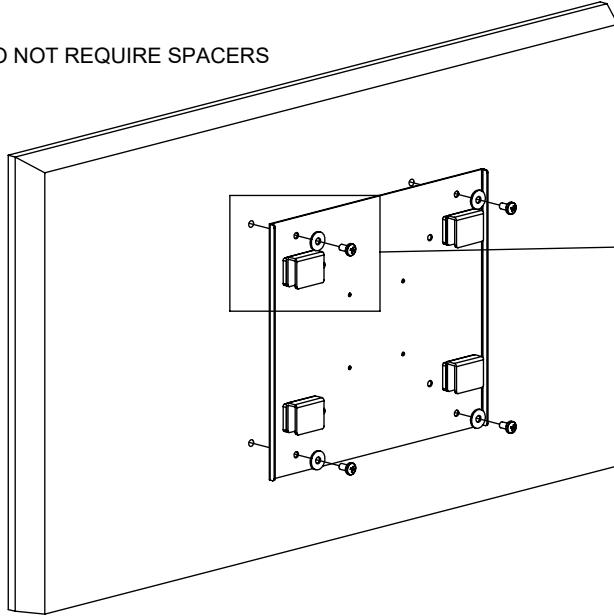

2

FOR TV's THAT REQUIRE SPACERS

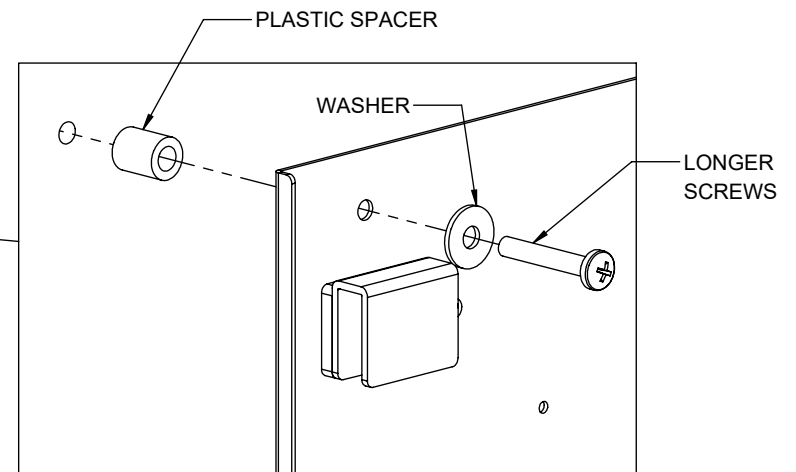
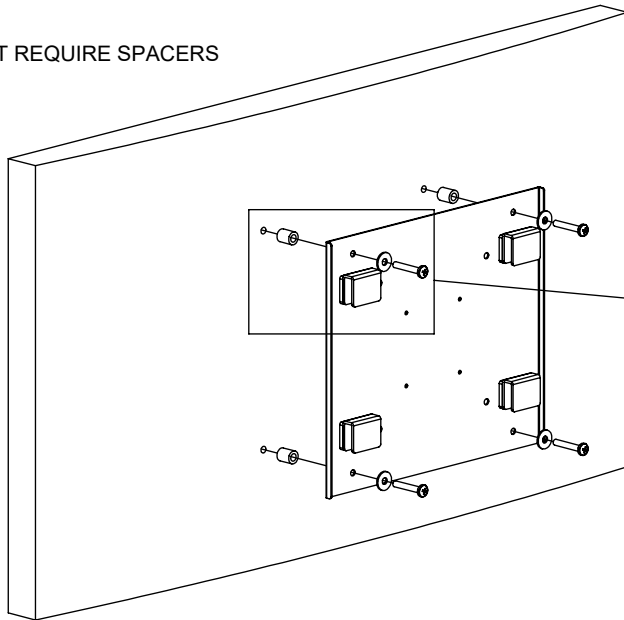

HANG T.V. ON HANG BARS

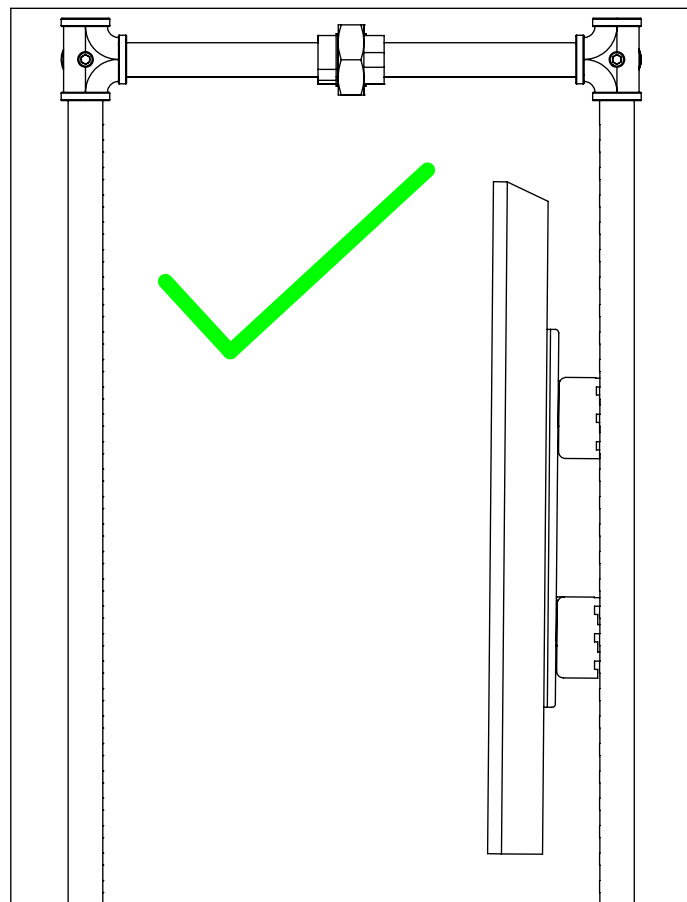
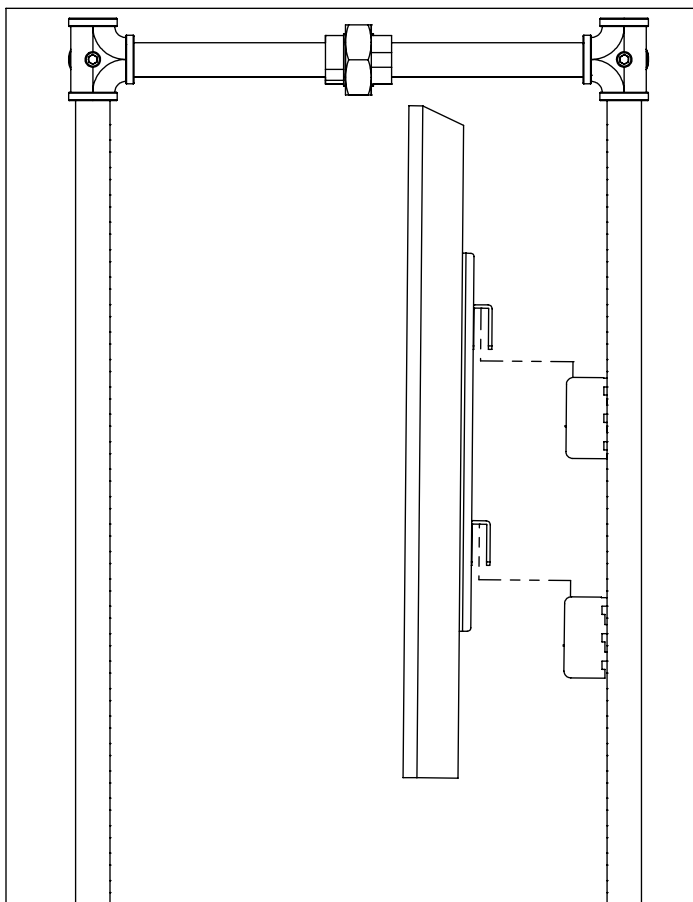

**ASSEMBLY INSTRUCTIONS:
PSORSLF48/24-ML**

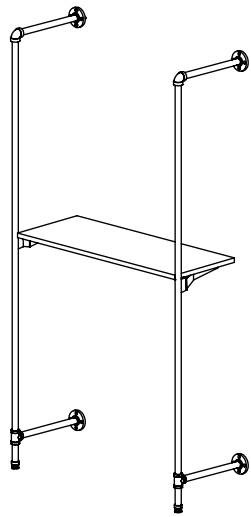

SHOWN INSTALLED
ON ITEM# PSOR FOR
REFERENCE

ITEM# PSORSLF48/24-ML

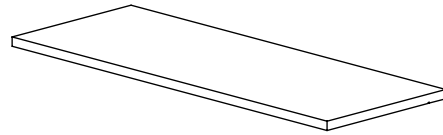

ITEM# PSORKB
(SOLD SEPARATELY)

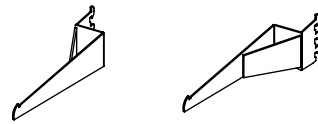

1

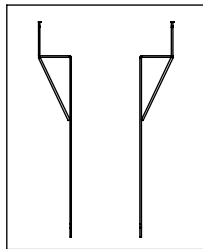

SHELF BRACKETS
VIEWED FROM BELOW

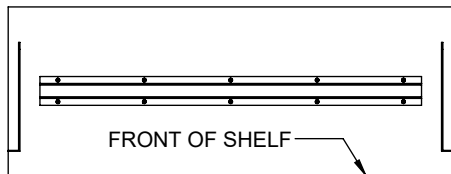

SHELF VIEWED FROM BELOW
**(NOTE: THE PSORSLF24-ML DOES
NOT HAVE A STEEL SUPPORT)**

IDENTIFY THE LEFT AND
RIGHT BRACKETS. THE
BEND OF THE SHELF
BRACKETS SHOULD BE
BETWEEN TWO OUTRIGGER
UPRIGHTS.

IDENTIFY THE FRONT OF
THE SHELF.

2

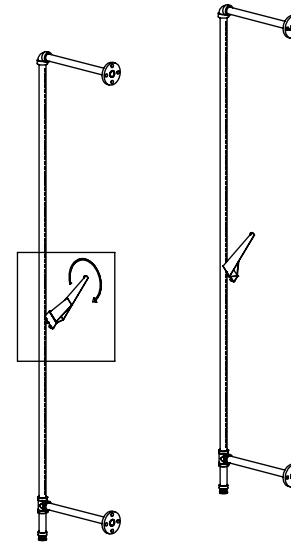

TILT THE SHELF BRACKET UP AND
INSERT THE TOP TOOTH INTO THE
DESIRED SLOT AS SHOWN. ROTATE
THE BRACKET DOWN WHILE
PUSHING TOWARDS THE UPRIGHT
SO ALL OF THE BRACKET TEETH
ENGAGE THE SLOTTED
STANDARDS. REPEAT FOR THE
OTHER BRACKET AT THE SAME
HEIGHT.

3

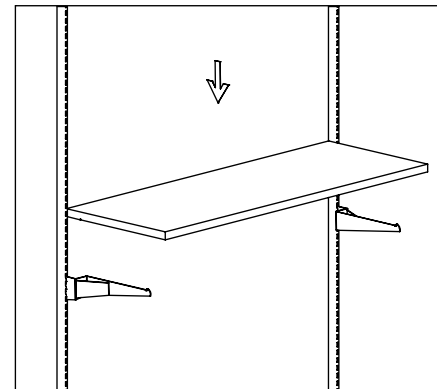

DROP THE SHELF ONTO THE
INSTALLED BRACKETS SO THE
BRACKETS ENGAGE THE
ROUTE ON THE BOTTOM OF
THE SHELF WOOD.